

CAPACITY	SYMBOL/ SERIAL NO.	CIRCUIT DIAGRAM
AC100V-240V, 50/60Hz		
12W		

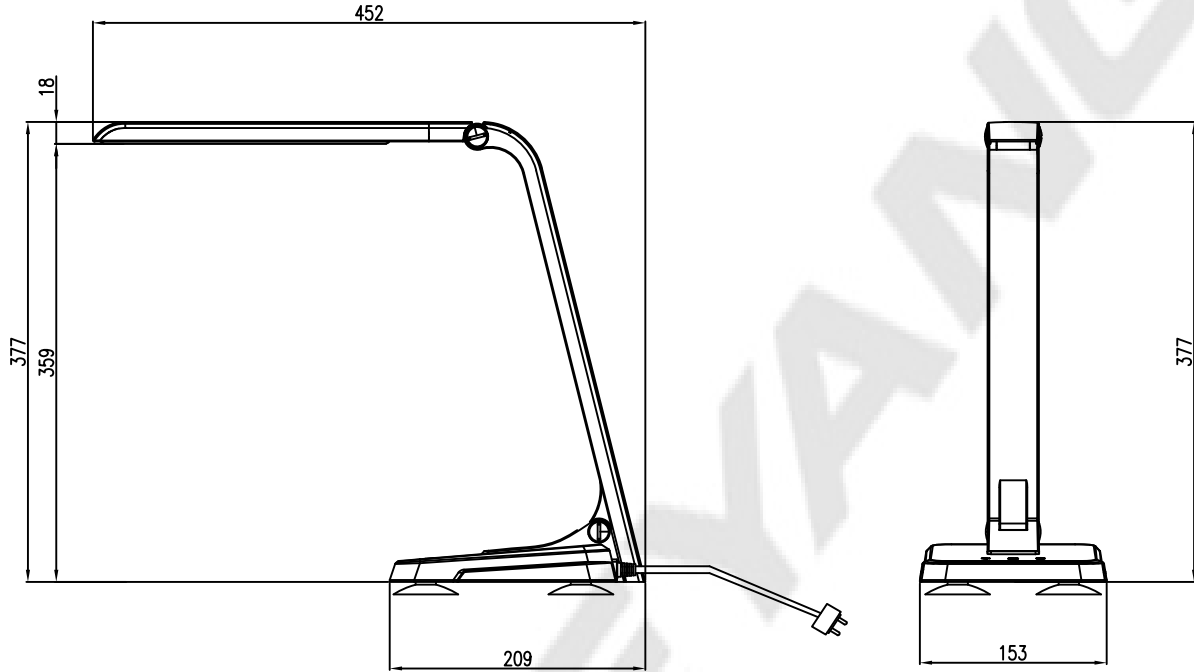

angle is adjustable : Left and right 45 degree

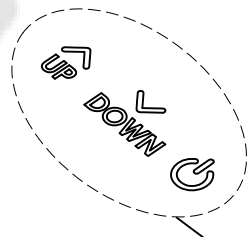
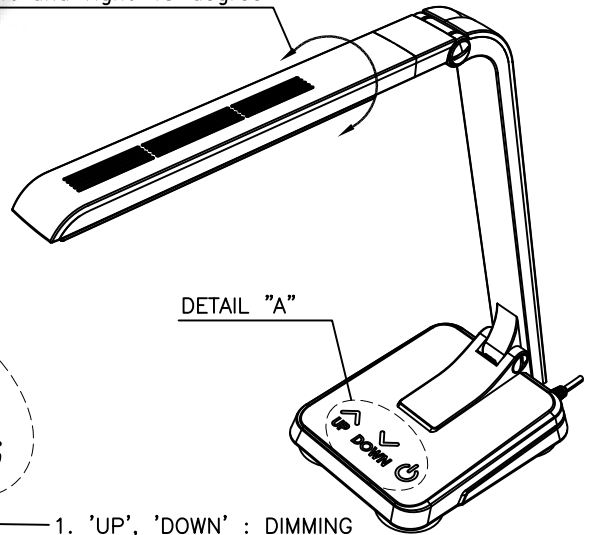

- 'UP', 'DOWN' : DIMMING
- POWER : ON/OFF

DETAIL " A "

-NOTE-

- W/1.6M CORD & PLUG
- MATERIAL : ABS
- COLOR TEMPERATURES : 2,700K

NO.	NAME OF PARTS	MATERIAL	Q'TY	REMARKS	NO.	NAME OF PARTS	MATERIAL	Q'TY	REMARKS
APPROVED	B. K. KIM	UNIT	MM	TITLE; LED DESK LIGHT (STAND TYPE) FOR MARINE USE					
CHECKED		SCALE	N/S						
DRAWING	B. I. KIM	COLOR	WHITE						
DATE	2015.12.04	IP	20						
					MODEL NO.	EL100-550RDPWC27	WEIGHT	1.2 Kg	
					DWG NO.	L14240058	SHEET NO.	15	